



OPERATOR'S MANUAL

ACCU-CUT J-5

Carpet and Vinyl Cut & Roll Machine

**For Parts or Service contact
Accu-Cut Support 1-800-222-8288**

Brockie International Inc. 28114 County Road 561, Tavares, Florida 32778
voice 800.222.8288 ♦ 352.742.0902 fax 352.742.0702
e-mail: info@accu-cut.com ♦ www.accu-cut.com

CONTENTS

INTRODUCTION	3
SAFETY PRECAUTIONS.....	4
ABOUT THE MACHINE	5
OPERATING PROCEDURES	6
<i>•Procedures for cutting</i>	
Loading the material-----	7
Unwrapping new & tightening loose rolls-----	7
Positioning the material-----	7
Entering the cut length-----	8
Setting the speed control-----	8
Rolling up the material -----	9
Monitoring the roll -----	9
Cutting the material-----	10
Wrapping the cut length -----	10
Dumping the cut length -----	11
<i>•Measuring roll balances</i>	
How to -----	11
<i>•Procedures for reverse rolling</i>	
Rolling up the material -----	12
A few words about reverse rolling-----	12
PLC / INTERFACE FEATURES.....	13-19
PREVENTIVE MAINTENANCE.....	20
TEST STRIP INSTRUCTIONS	21
ELECTRICAL DIAGRAM	22
PARTS LIST	23
WARRANTY CERTIFICATE.....	32

INTRODUCTION

Congratulations on the purchase of your Accu-Cut J-5 carpet and vinyl cutting and rolling machine. Your Accu-Cut machine has been carefully engineered and manufactured to provide you with many years of dependable service and trouble free operation.

Proper operation and maintenance is essential to ensure precise and dependable operation of your Accu-Cut. We encourage you and your employees to read this manual carefully and become familiar with the operating and maintenance procedures for this machine.

This manual is designed to cover all areas of operation, maintenance, and troubleshooting in order to minimize problems. Always follow safety rules and precautions when operating or performing maintenance work on the machine.

Again, congratulations and thank you for choosing Brockie International to provide you with quality equipment and quality service. The confidence you and thousands of others have placed in us has helped to make Accu-Cut the most respected name in floor covering cutting equipment. Should you ever have any questions or concerns regarding your Accu-Cut please do not hesitate to contact us.

BROCKIE INTERNATIONAL, INC.

SAFETY PRECAUTIONS

In order to avoid personal injury, make sure the operator(s) and/or maintenance person(s) of the machine have been oriented with the machine's operating procedures and are aware of all safety precautions.

1. **Unplug power cord before making any adjustments or repairs.**
2. **A qualified electrician should perform electrical repairs.**
3. **Do not operate machine on a wet floor.**
4. **Use extreme caution when replacing cutter blades.**
5. **Keep hands clear of all moving components while machine is running.**
6. **Keep loose clothing and articles away from all moving components while machine is running.**
7. **Keep machine unplugged while not in use.**
8. **Do not allow children near the machine.**
9. **Keep machine clean of all plastic wrap, carpet fibers, and all other debris.**
11. **Ensure machine is stationary and will not roll on casters.**
12. **Do not remove chain covers except for servicing.**
13. **Keep space beside cradles (dumping areas) clear.**

ABOUT THE MACHINE

The Accu-Cut J-5 cut and roll machine consists of two sets of steel rollers that are referred to as cradles. The side where material is loaded is the **load side cradle**, while the opposite side is the **roll up cradle**. The roll up cradle is designed to run slightly faster than the load side to ensure a tight roll up of material. Each cradle is chain driven by heavy duty UL & CSA approved electric motors.

The J-5 is operated from the **control panel**, which includes the **directional controls**, **variable speed control**, **cutter controls**, and the **electronic, auto-stop counter**.

The Accu-Cut J-5 measuring system is extremely accurate. It consists of a large diameter, knurled **measuring wheel** located in a cutout of the **inspection table** below the **hold down arm**. The measuring wheel is connected to an advanced encoder which communicates with the electronic, auto-stop counter to provide you with an accurate measurement.

The cutter assembly on the J-5 consists of two, standard, slotted blades positioned within a cutter assembly inside the **cutting track**. The cutter assembly is chain driven by a dedicated cutter motor. The rubber o-rings on the wheels of the cutter assembly are removable and are mainly beneficial when cutting vinyl - they are not required when cutting carpet.

A wrap around **foot control cable** is provided to operate the machine "hands free" while inspecting wrapping, unwrapping, or tending the roll.

The J-5 also includes a **dumping mechanism** on the **roll up cradle** that will quickly and simply offload the cut material onto the floor allowing another cut to be made without using a forklift to unload the cut piece.

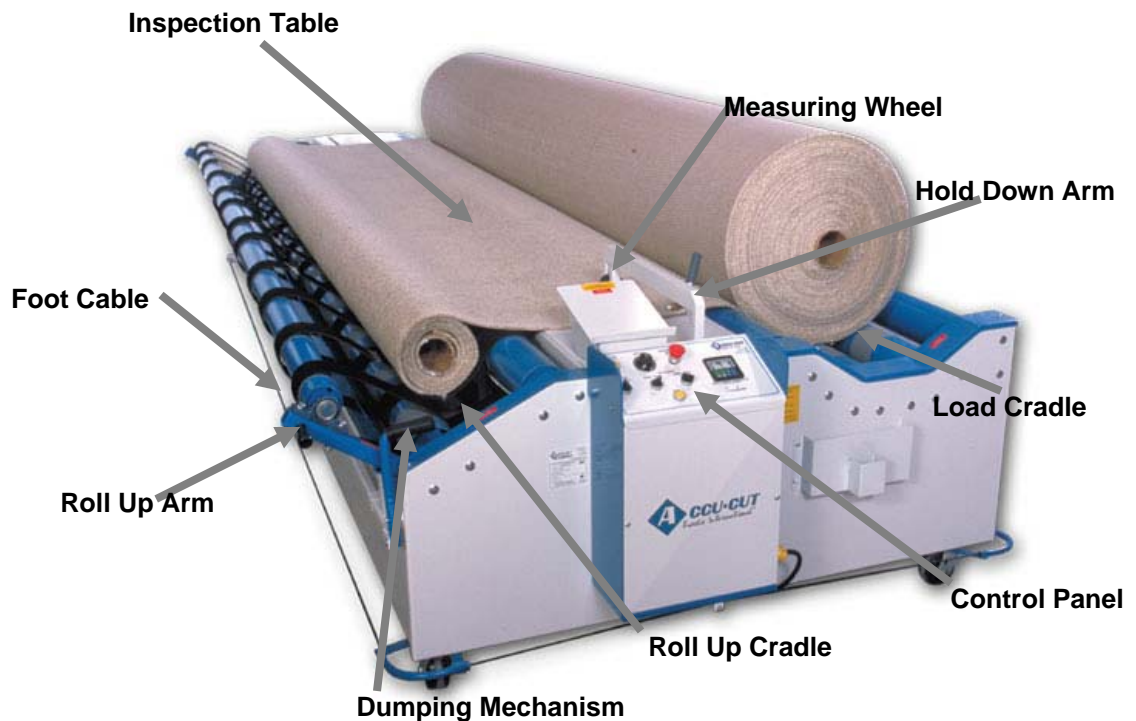

OPERATING PROCEDURES

Congratulations on your purchase from Brockie International. This machine is equipped with an advanced microprocessor P.L.C. unit to ensure accurate measurement. To communicate with this P.L.C. we have provided a user-friendly interface. Simply enter your commands into the keypad and watch the machine do the work for you.

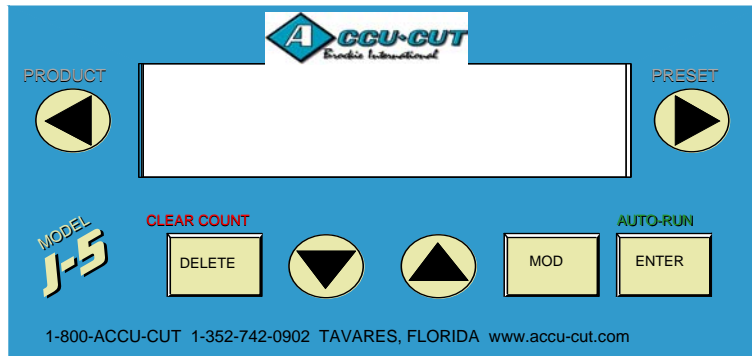

Arrow Keys-	Data entry (used for entering numeric data after MOD is pressed)
Left / Right Arrow-	Moves cursor left/right
Up / Down Arrow-	Increments / Decrements value by 1
Product Key/Left Arrow-	Scrolls the various products (scale factors)
Preset Key/Right Arrow-	Scrolls through various presets (preset lengths)
Delete/Clear Count-	Clears the counter value
Mod Key-	Press to begin change of data
Auto Run Key-	Places machine in Auto-run Mode





Password Protection

This unit is equipped with a "Password Protection" feature. Every time the machine is turned off or is unused for a designated time the machine prompts the user to

```

-----
| ENTER  PASSWORD |
|          ****   |
|-----|
    
```

To enter the password:

1. Press (all data begins to blink)
 2. Press  (one digit begins to blink)
 3. Press  to increment or decrement the value
 4. Repeat steps 2 & 3 for remaining digits till desired value is displayed
 5. Press  when the 4 digit number is entered
- (Factory preset is 4321)  

You have now gained access to the machine and may begin to roll, measure and cut the product



PROCEDURES FOR CUTTING

PROCEDURES FOR UNROLLING AND CUTTING

Loading the material

Place the material on the **load side cradle**, making sure the leading edge of the material is feeding across the **inspection table** from the **bottom of the roll** with the **pile side up and the backing down** – vinyl can be measured pattern up or down. Make sure the roll is positioned so that the edge of the material is between the **measuring wheel** and the **cutter assembly** (see photo 1A).



Photo 1A

Unwrapping new rolls and tightening loose rolls

After loading the wrapped roll, cut the plastic the full length of the roll and at each end. Position the load cradle **roller directional switch** in the reverse position, and then step on the **foot cable control** while pulling off the plastic wrapping.

If you have a loose roll, run the **load cradle** rollers in reverse by placing the load cradle **roller directional switch** in the reverse position and pressing the **jog button** or stepping on the **foot cable control** to activate the load cradle rollers. Continue to run the rollers in reverse until the roll has tightened.

Positioning the material

Raise the **hold down arm**, lifting it off the **measuring wheel**. Set both **roller directional switches** to forward. Step on the **foot cable control** or press the **jog button**, advancing the material to the center of the **cutting track** (see photo 3A). Now lower the **hold down arm** back on to the **measuring wheel**. Failure to lower the **hold down arm** will result in an inaccurate measurement.

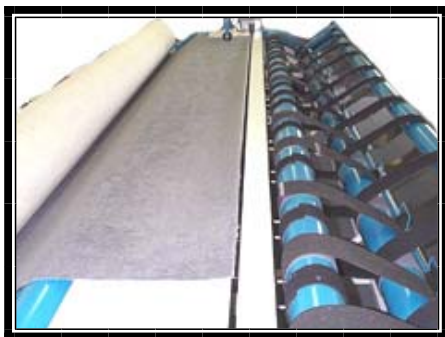

Photo 3A

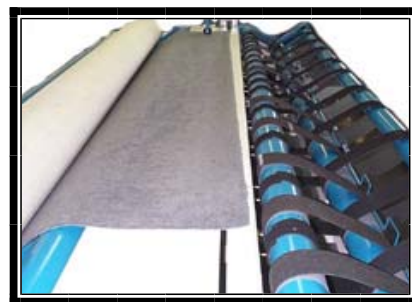

Photo 3B

Note: If the material is off square, line the trailing edge of the material with the **cutting track** (see photo 3B).

PROCEDURES FOR CUTTING

Setting Preset Length

This unit is equipped with a multi-preset feature that enables the user to enter the required length of material into the machine's memory. This will prompt the machine to automatically slow down the rolling process approximately one foot before the desired length has been reached. It then slowly rolls to the preset length.

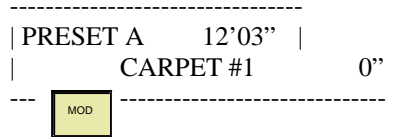

To enter a preset length:

1. Press

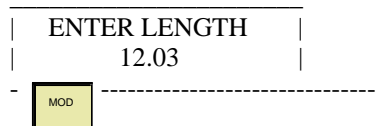

2. Press  (all data begins to blink)

3. Press   (one digit begins to blink)

4. Press  to increment or decrement the value

5. Repeat  steps 2 & 3 for remaining digits till desired value is displayed

5. Press  when the 4 digit number is entered

Your desired length is now entered into the counter. You are now ready to roll and cut the product.

Setting the speed control

The speed at which the rollers turn can be quickly and simply adjusted by turning the **variable speed control knob** located on the control panel. Keeping the speed at a low setting when beginning the roll up process and increasing the speed as the roll increases in size is recommended.



Photo 5

PROCEDURES FOR CUTTING

Rolling up the material

After setting the **counter**, either press the **hand control button** or step on the **foot cable control**, while pulling the material across the inspection table and under the hold down arm by hand. Advance the leading edge of the material until it is half way between the last two rollers on the **roll-up cradle** (see *photo 8A*). Pulling up the **roll-up arm** will fold over the material and start the roll-up procedure. If using a tube, place the tube on top of the material, then pull up the **roll-up arm** folding the material over the tube (see *photo 8B*).



Photo 8A



Photo 8B

Continue to apply pressure with the **roll-up arm** until the material has made six or seven revolutions (see *photo 8C*). At this time the **roll-up arm** can be lowered to its original position (see *photo 8D*). Now the machine can be operated while stepping on the **foot cable control** allowing the roll to easily be monitored and adjusted if necessary.



Photo 8C



Photo 8D

Monitoring the roll

Make sure the roll-up is started tight and square. If the roll begins to “walk” one way or the other, move to that end of the roll and push the roll in towards the **inspection table** as it rolls. This will cause the side walking to catch up with the other side straightening the roll and reducing any “coning” of the roll. Do not be concerned if the roll appears somewhat loose. After the cut has been made, or the end of the roll is reached, continuing to rotate the roll in the **roll-up cradle** will cause the material to tighten.

PROCEDURES FOR CUTTING

Cutting the material

When the counter approaches the programmed measurement the machine will automatically slow down and stop precisely at the programmed length. Before activating the cutter ensure the material is tight across the **cutting track**. If the material is not tight, positioning the roll-up cradle **roller directional switch** in forward and the load cradle **roller directional switch** in reverse and briefly pressing the **hand control button** will tighten the material across the **inspection table**.

Once the material is tight across the **cutting track**, engage the cutter by turning and holding the **cutter directional switch** to the direction desired then press and hold down the **cutter safety button**. Releasing the button or switch will stop the cutter. When the cutter has reached the end of the **cutting track** it will automatically come to a stop. The cutter cuts in both directions allowing it to be left at either end of the machine after a cut has been made.

Note: When processing 15' wide material the cutter must be stored at the **control panel** end of the machine. If the cutter is left at the far end of the machine it will interfere with the material as it moves across the **inspection table**.

Wrapping the cut length

To wrap the cut length, keep the roll-up cradle **roller directional switch** in the forward position and place the load cradle **roller directional switch** in the off position. Place the wrapping material inside the flap of the material you are wrapping. Stepping on the **foot cable control** will rotate the roll, letting you wrap the material while it is still on the machine.



Photo 11A



Photo 11B

Caution: Keep hands and all loose clothing away from moving parts.

PROCEDURES FOR CUTTING

Dumping the cut length

The cut length can be dumped on to the floor by pulling the **dumping mechanism** that lowers the **roll-up arm** into the dump position. When the **roll-up arm** is in the dump position the cut length will fall to the floor. For smaller cut lengths it may be necessary to engage the roll-up side cradle to dislodge the material from the cradle to the floor or simply push the material to the floor by hand.



Photo 12A

Dumping
mechanism



Photo 12B



Photo 12C

Caution: Make sure the area is clear before dumping the cut length.

MEASURING ROLL BALANCES

MEASURING ROLL BALANCES

To determine the balance remaining on a roll or to check the following procedures:

PRESET

length of a new roll perform the

- ◆ Scroll through the preset measurements using the key until “no stop” is reached. This allows the machine to run without stopping when a programmed length is reached.
- ◆ Line **CLEAR COUNT** up the edge of the material to be measured to the cen- ter of the **measuring wheel** pile side up. (see *photo 13*).
- ◆ **Press** to reset the counter to zero.
- ◆ Follow the procedures for “*Rolling up the material*” detailed on page 9.
- ◆ Continue rolling up the material until the final few feet of the roll is reached. At this point put the machine in the low speed setting and continue advancing the material until it is centered with the **measuring wheel**.
- ◆ The measurement indicated on the counter is the length of the material.



Photo 13

Note: Failure to slow down the rollers at the end of the measurement may result in the measuring wheel continuing to turn *and* measure even after the trailing edge of the material has passed the wheel. This will result in an inaccurate measurement.

PROCEDURES FOR REVERSE ROLLING

PROCEDURES FOR REVERSE ROLLING

Reverse rolling is an effective manner of merchandising remnants. Several dealers even merchandise full rolls pile side out. An optional **top counter** and **pinch roller** may be necessary for reverse rolling full rolls. Contact your Accu-Cut representative for details on these options.

The procedures for reverse rolling are identical to the procedures for “*Measuring roll balances*” (page 10) with the following exceptions:

Rolling up the material

After setting the **counter**, either press the **hand control button** or step on the **foot cable control**, while pulling the material across the inspection table and under the hold down arm by hand. Advance the leading edge of the material until it is half way between the last two rollers on the **roll-up cradle** (see photo 14A). Position the material on top of the tube. Use of a tube is strongly recommended.

Leave the load cradle **roller directional switch** in the forward position but place the **roll-up cradle roller directional switch** in the reverse position.

Pull up the **roll-up arm** and engage the rollers by stepping on the **foot cable control** or pressing the **jog button**. The **roll-up arm** will cause the material to begin rolling in reverse around the cardboard tube and start the roll-up procedure. (see photo 14B). After the material has made several revolutions lower the roll-up arm. (see photo 14C).

NOTE: If the material is walking up on the inspection table momentarily shut off the roll-up cradle to allow load cradle to catch up.



Photo 14A



Photo 14B



Photo 14C

A few words about reverse rolling

Reverse rolling is a simple process but often takes time to perfect and learn – be patient. There are numerous times when and how reverse rolling can occur. We have tried to list the most common below.

Reverse rolling the balance of a roll after making a cut:

After removing the cut length from the roll-up cradle, reverse the material in the load cradle so that the leading edge is centered with the measuring wheel. Reset the counter to zero then follow the steps at the top of the page. The measurement indicated on the counter is the length of the material.

Reverse rolling with the material coming off the top of the roll and pile side down:

If the length of a roll is already known, some operators will choose to reverse roll the material having the material feed from the top of the roll with pile side down. This method allows the operator to keep roll-up cradles in the forward position, load side reverse and use the roll-up arm in the same manner as when making a cut. *Please note that it is not possible to get an accurate measurement with the pile side down.*

PLC / INTERFACE FEATURES

Multi-Cutting

This unit is equipped with up to five pre-programmed lengths. You now have your first preset selected.

To change to another preset press  This will change your preprogrammed length. To program

all 5 presets simply repeat the procedure described in “Setting Preset Length”. Once you have completed this, the lengths are stored in the memory of the machine and remain present even when the machine is unplugged. This feature is very useful when cutting a series of same size pieces for a given house plan for example.

This unit also has a “no stop” setting. During this process if the counter preset is set to no stop

(accessed by pressing  the unit will never stop nor slowdown. This is useful if the customer want to

measure entire rolls or a length that is undetermined.

Rolling the Product

To roll product:

1. Bring carpet to the center of the cutting bar.
2. Verify that your desired carpet length is in the display
3. Press  to clear the counter
4. Advance the carpet to the middle of the belts
5. Lift the roll-up cradle
6. Run the machine until it stops
7. Verify the count (reverse direction if necessary)

PLC / INTERFACE FEATURES

Cutting the Carpet

Now that you have accurately measured the carpet you are ready to proceed with a cut.

- To make a cut:
1. Press the **CUTTER BUTTON**
 2. Turn the **CUTTER SWITCH** in the direction you wish the cutter to travel

This activates the bi-directional cutter.

NOTE: *Ensure that the cutter track is free of any obstructions before activating the cutter*

NOTE: *Keep hands free from the cutter and its track at all times*

NOTE: *It may be necessary to return the cutter assembly to the control end for wider material so the cutter will not obstruct the material*

NOTE: *Return the cutter to the control when the machine is not in use*

Multiple Scale Factors

Sometimes different products grip the count wheel differently due to their adhesive nature. We have taken this into consideration by allowing this machine to retain three separate scale factors to accommodate a variety of materials. Different product may be selected at any time by pressing . This changes the screen to display another product.

Examples of different presets measuring differently:

Scroll product once:

```
-----  
| PRESET A    12'03" |  
| CARPET 1    12'03" |  
-----
```

Scroll product twice:

```
-----  
| PRESET A    12'03" |  
| CARPET 2    12'04" |  
-----
```

Scroll product thrice:

```
-----  
| PRESET A    12'03" |  
| VINYL       12'03" |  
-----
```

➤ The user is responsible to verify the accuracy of the count for the product sold and to required certification. The manufacturer or its agents cannot be held responsible for any inaccuracies in cut lengths.



◀ arrange for any in-

PLC / INTERFACE FEATURES

Auto-Run

This unit is equipped with an auto-run feature once. This lets the unit roll automatically to a preset length.



To use the Auto-Run feature:

1. Follow the procedure in setting the preset length
2. Bring carpet to the center of the cutting bar
3. Verify that your desired carpet length is in the display
4. Press  to clear the counter
5. Advance the carpet to the middle of the belts
6. Lift the roll-up cradle
7. Press  (an A appears in the lower right corner to signify auto-run mode)

The unit will now automatically unroll the carpet to the preset length slowdown and stop.





NOTE: The user must pay full attention to the machine at all times.

Master User's Menu

This counter may be tailored to better suit the user of the machine. When 2 fingers are depressed on the  and  the MASTER PASSWORD is brought up.

```
-----  
| MASTER  PASSWORD |  
|          XXXX    |  
|-----|
```

To enter the master password :

1. Press  (all data begins to blink)
2. Press  (one digit begins to blink)
3. Press   to increment or decrement the value
4. Repeat steps 2 & 3 for remaining digits till desired value is displayed
5. Press  when the 4 digit number is entered (the master password is 4321)

Upon entering the correct password you now have gained access to the Master Users Menu.

Use the  to scroll left and the  to scroll right and see the various features.





PLC / INTERFACE FEATURES

Changing the Password

The four-digit security code is changeable for your convenience.

| ENTER NEW PASSWORD |
XXXX

To enter a new password :





1. Press  (all data begins to blink)
2. Press  (one digit begins to blink)
3. Press   to increment or decrement the value
4. Repeat steps 2 & 3 for remaining digits till desired value is displayed
5. Press  when the 4 digit number is entered

Changing the Timer:

There is an adjustable timer which disables the machine when it is left unused for a pre-determined length of time. It is adjustable for your convenience.

| NEW PASSWORD TIMER |
XXX SECONDS

To enter a new password :

1. Press  (all data begins to blink)
2. Press  (one digit begins to blink)
3. Press   to increment or decrement the value
4. Repeat steps 2 & 3 for remaining digits till desired value is displayed
5. Press  when the 4 digit number is entered

NOTE: If the password is set to 0 the counter no longer asks the user for a password upon startup.

NOTE: Always unplug the machine when not in use!





PLC / INTERFACE FEATURES

Change Blade:

There is a reminder message that can be prompted to remind the user to change the blade to aid in providing clean cuts.

```
-----  
| CHANGE BLADE AFTER |  
|       XXX CUTS     |  
|                     |  
-----
```

To change the number of cut before being reminded:

1. Press  (all data begins to blink)
2. Press  (one digit begins to blink)
3. Press   to increment or decrement the value
4. Repeat steps 2 & 3 for remaining digits till desired value is displayed
5. Press  when the 4 digit number is entered

After the per-determined amount of cuts have been made the user will be prompted with the following :

```
-----  
| CHECK / CHANGE BLADE |  
|   PRESS ENTER       |  
|                     |  
-----
```





The machine is temporarily disabled. Once the user presses  they will re-gain full functionality.

Imperial or Metric

Your carpet cutting machine is also capable of measuring in either metric or imperial units

```
-----  
| 1 IMPERIAL 2 METRIC |  
|           1         |  
|                     |  
-----
```

To change the setting:

1. Press 
- 2.. Press   to increment or decrement the value
3. Press  when the 4 digit number is entered





PLC / INTERFACE FEATURES

Slow down

Your machine slows before it comes to a stop to avoid rolling to much carpet. The length at which it does this is adjustable.

SLOW DOWN 228

To change the setting:

1. Press  (all data begins to blink)
2. Press  (one digit begins to blink)
3. Press   to increment or decrement the value
4. Repeat steps 2 & 3 for remaining digits till desired value is displayed
5. Press  when the 4 digit number is entered





NOTE: Factory default is 228 which is about 1 ft or 30 cm. This should be suitable for the majority of applications.

FS Auto Run

This is the setting that determines whether auto run is enabled. If this is set than the auto run feature can be activate by both the footswitch and . 

1 NO	2 FS AUTO
	1

To change the setting:

1. Press 
- 2.. Press   to increment or decrement the value
3. Press  when the 4 digit number is entered

NOTE: Factory The autorun will only begin once you remove your foot from the foot switch or . 
Either must have been held down for 2 seconds to avoid accidental tripping.





PLC / INTERFACE FEATURES

Calibrating the Machine

The calibrate CARPET 1, CARPET 2, VINYL are all designed in case one finds out that their machine is measuring inaccurately.

```
-----  
| CALIBRAT CARPET 1 |  
|           228000   |  
|-----|
```

To change the calibration:

1. Press  (all data begins to blink)
2. Press  (one digit begins to blink)
3. Press   to increment or decrement the value
4. Repeat steps 2 & 3 for remaining digits till desired value is displayed
5. Press  when the 4 digit number is entered

NOTE: *Factory setting is 228000 and is right for 98% of applications!*

Floating Reset:

PLEASE LEAVE THIS AT 0.

PREVENTIVE MAINTENANCE

Weekly:

1. **Check conditions of belts and belt lacing.** Repair, if possible, any damaged belt lacing contact Accu-Cut for replacement belts.
2. **Check control switches** for proper operation.
3. **Check operation of counter assembly.**
 - ◆ Check that measuring wheel is secure and does not have any cracks or excessive wobble.
 - ◆ Check the “grooves” or “knurls” on the measuring wheel. Ensure the wheel does not have smooth or bald spots.
 - ◆ Make sure wheel is at proper height above opening in the table. Wheel must be at least a credit card thickness above opening or the pads on either side of the opening.
 - ◆ Check condition of measuring wheel shaft and its connection to the counting device. Make sure the shaft is secure and not bent.
4. **Clean machine** of debris and/or carpet fibers, particularly on or around the motor areas, chains, sprockets and cutting track.
5. **Check tension on all cables and chains.** Adjust as necessary for proper operation.
6. **Check calibration of counter.** Follow the Test Strip Instruction sheet in this manual to check your calibration. Contact your Accu-cut Service Representative before attempting re-calibration.

Monthly:

1. **Check the alignment** of all sprockets, pulleys and rollers for proper operation.
2. **Check allen screws** on all sprockets, pulleys and locking collars.
3. **Check condition of the electrical outlet** on machine. Ensure outlet is secure.
4. **Check gearboxes** for proper oil level. Use 90-weight gear oil, if needed.
5. **Lubricate all drive chains** with light oil.

Yearly:

1. **Lubricate all roller bearings** with grease gun
2. **Lubricate all bearings for cutter drive assembly** with grease gun.
3. **Lubricate counter shaft bearings** with grease gun.
4. **Lubricate swivel castor wheels** with grease gun.

TEST STRIP INSTRUCTIONS

How to make a test strip:

1. Cut a strip of carpet that is 4 " wide by 13' long.
2. Center your tape measure on strip of carpet.
3. Draw a line at 0 and a line at 12'.
4. DO NOT cut off excess material.

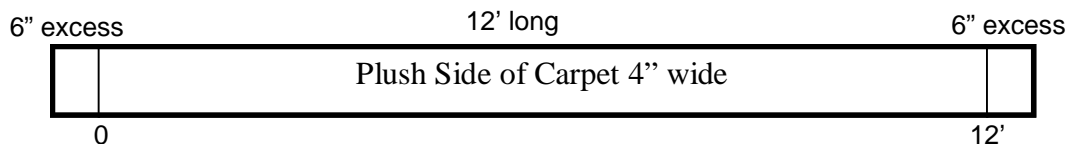

How to use a test strip:

1. Unwind test strip plush side up, line up the black hold down arm over wheel with 1st black line on test strip.
2. Reset counter to zero.
3. Slowly pull test strip across the measuring wheel.
4. Stop at 2nd black line, counter should read 12 feet.
5. Repeat the test 3 or 4 times.
6. If measurement is off contact your Accu-Cut Service Representative.

ELECTRICAL DIAGRAM

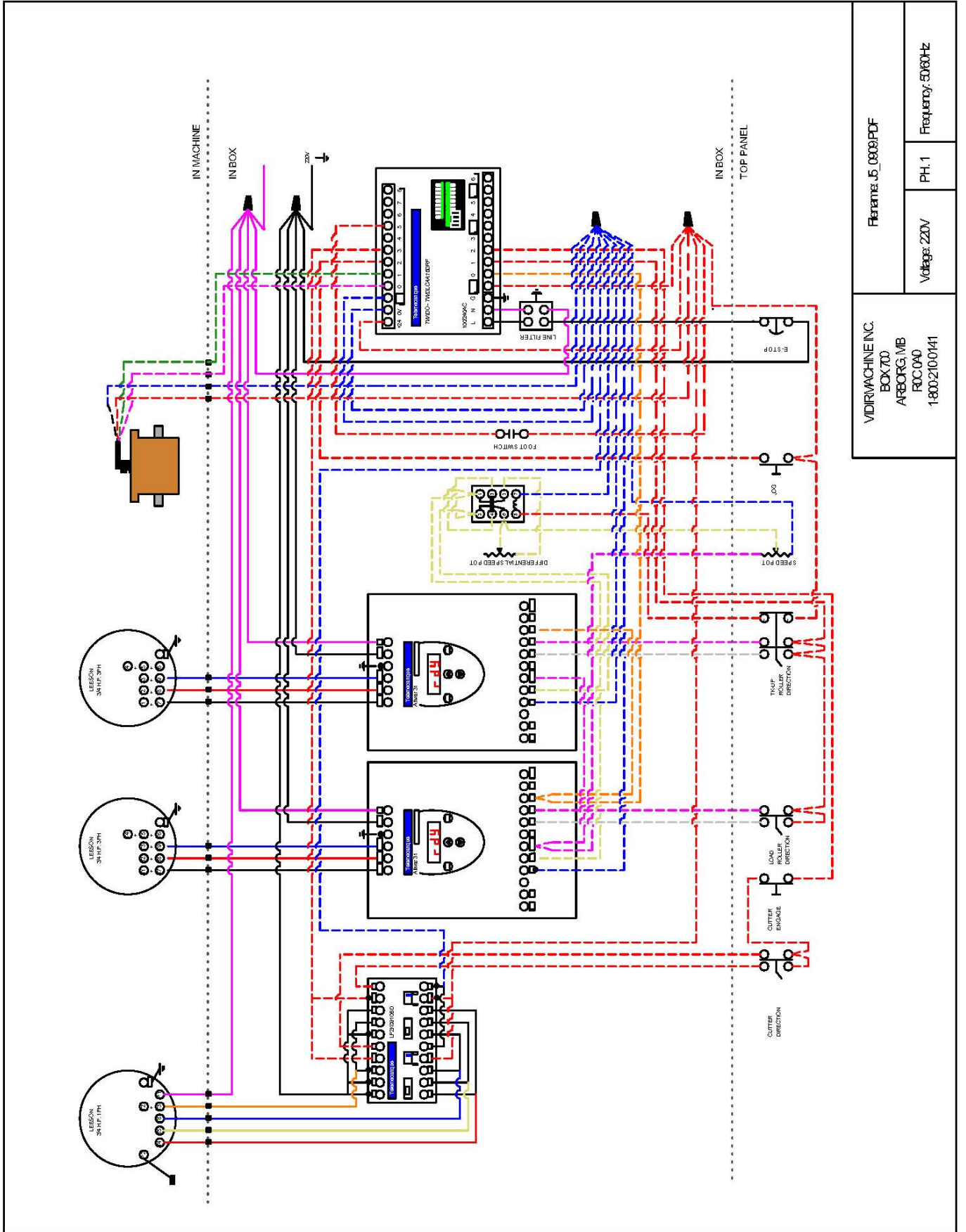

Filename: J5_0809.PDF

VIDIR MACHINE INC.
 BOX 700
 ARBORG, MI
 ROC 040
 1-800-210-0141

Voltage: 220V

PH: 1

Frequency: 50/60Hz

J-5 Parts—Load Cradle

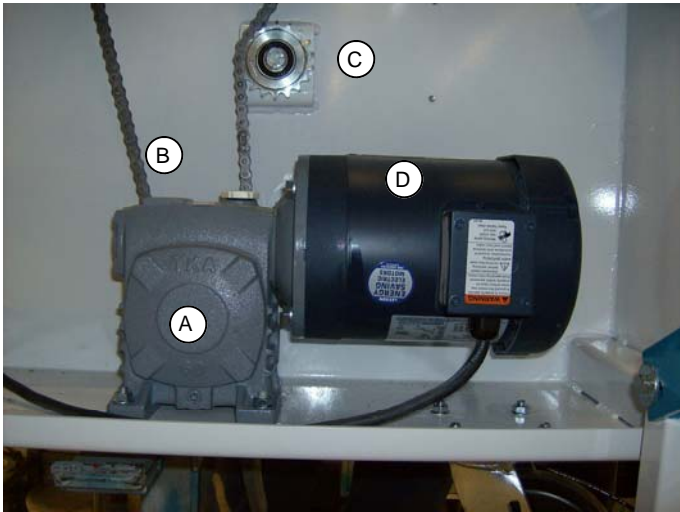

Photo 1

Load Cradle—Photo 1

<u>Ref</u>	<u>Description</u>	<u>Part Number</u>
A	Gearbox	107-0012
B	Sprocket 4020	120-0042
C	Idler 4018	120-0039
D	Drive Motor	407-0027

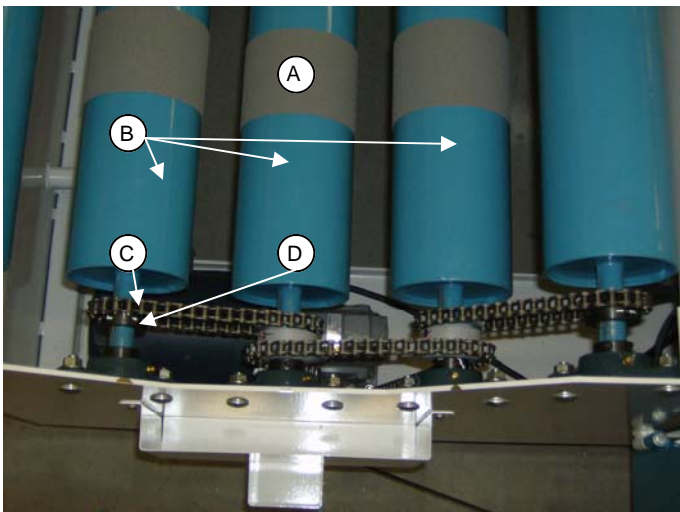

Photo 2

Load Cradle—Photo 2

<u>Ref</u>	<u>Description</u>	<u>Part Number</u>
A	Grip Tape 5" Roller	8-53803
B	Load Roller 5"	8-44776
C	Load Drive Chain 2	8-53792
D	Sprocket 4016	120-0033

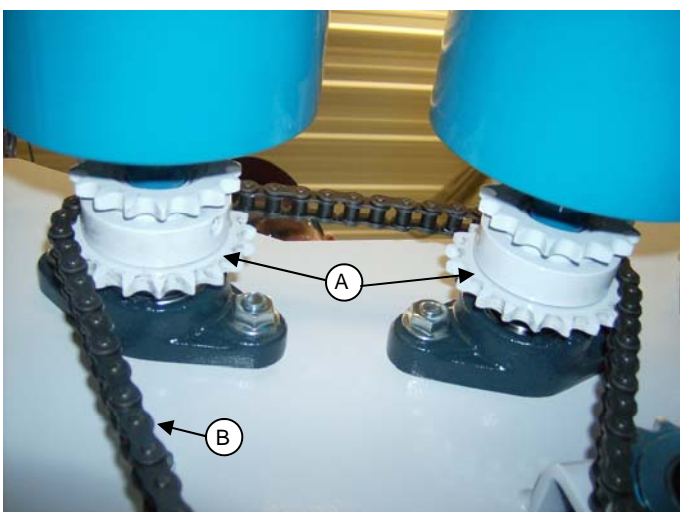

Photo 3

Load Cradle—Photo 3

<u>Ref</u>	<u>Description</u>	<u>Part Number</u>
A	Double Sprocket	8-53323
B	Load Drive Chain 1	8-53791

J-5 Parts—Counter



Photo 1

Counter—Photo 1

<u>Ref</u>	<u>Description</u>	<u>Part Number</u>
A	Cutter Cover	8-46959

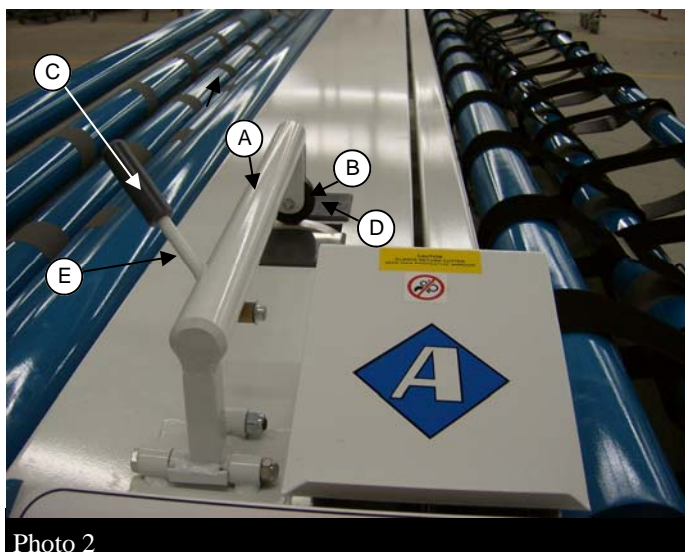

Photo 2

Counter—Photo 2

<u>Ref</u>	<u>Description</u>	<u>Part Number</u>
A	Counter Arm	8-46937
B	Counter Wheel	104-0002
C	Handle	7-1170
D	Counter Plastic Plate	8-1570
E	Counter Handle	8-46942

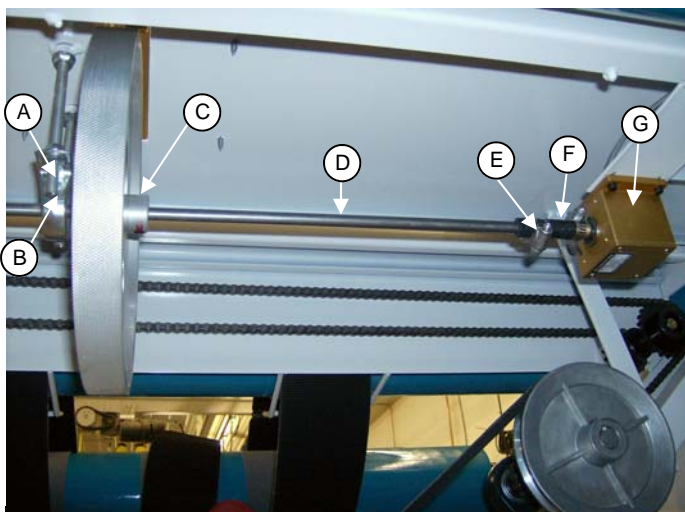

Photo 3

Counter—Photo 3

<u>Ref</u>	<u>Description</u>	<u>Part Number</u>
A	Bearing Assembly	8-52907
B	Bearing Holder	006-0053
C	Counter Wheel 10"	402-0030
D	Encoder Shaft	8-1550
E	Hose Clamp	111-0016
F	Coupler	402-0005
G	Encoder	402-0042

J-5 Parts—Cutter

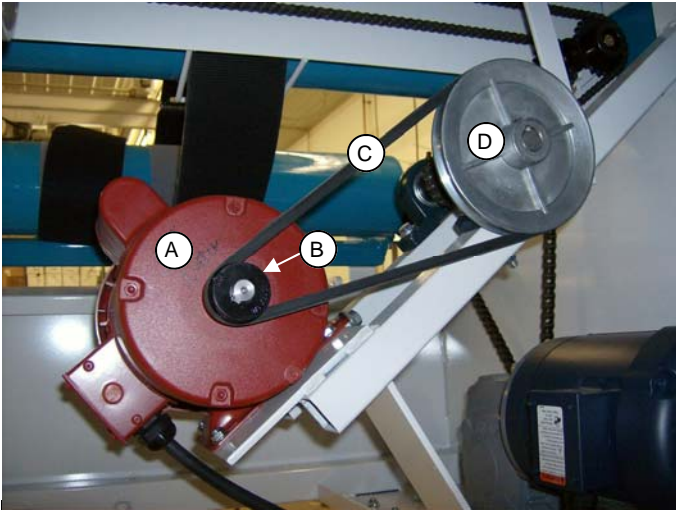

Photo 1

Cutter—Photo 1

<u>Ref</u>	<u>Description</u>	<u>Part Number</u>
A	Motor	407-0003
B	Pulley	115-0070
C	Belt A32	102-0024
D	Pulley	115-0024

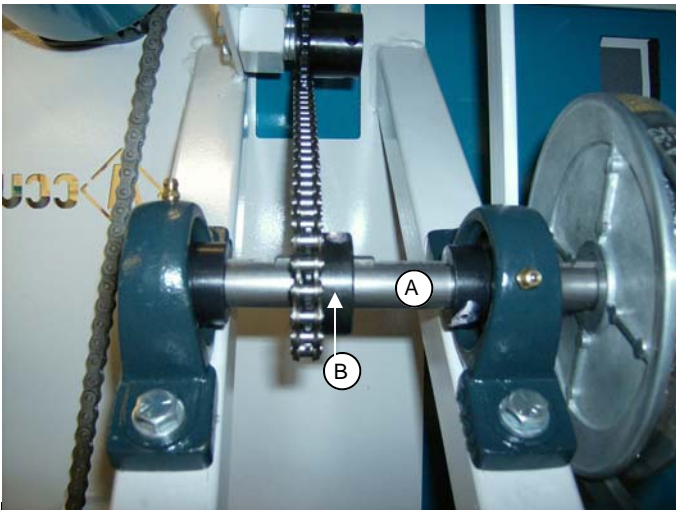

Photo 2

Cutter—Photo 2

<u>Ref</u>	<u>Description</u>	<u>Part Number</u>
A	Driveshaft	8-44689
B	Sprocket 3517	120-0013

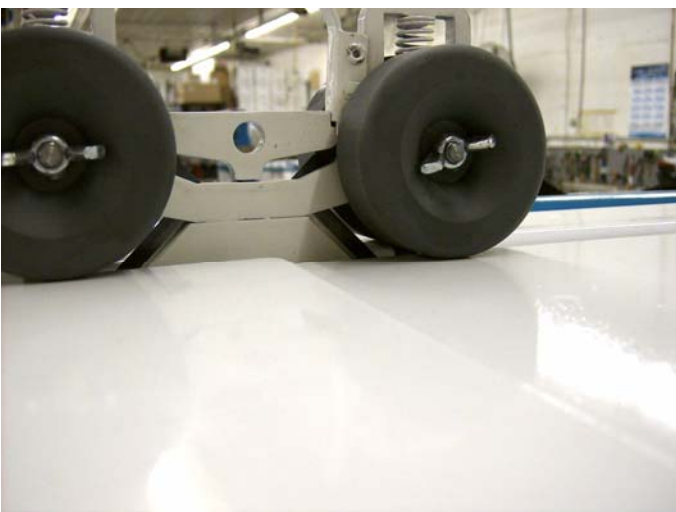

Photo 3

Cutter—Photo 3

<u>Ref</u>	<u>Description</u>	<u>Part Number</u>
	Cutter block Complete	8-44271

J-5 Parts—Cutter

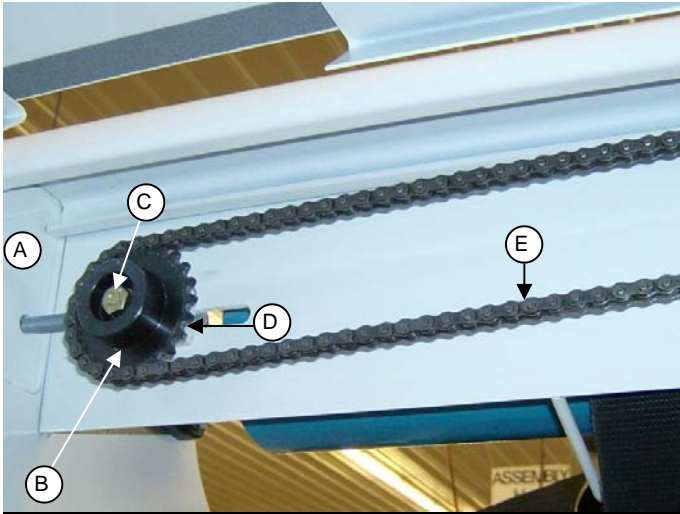

Photo 1

Cutter—Photo 3

<u>Ref</u>	<u>Description</u>	<u>Part Number</u>
A	Cutter Back Cover	8-44195
B	3523 Sprocket	120-0067
C	3/8" x 4 Bolt	001-0255
D	Tightener Block	8-5330
E	J5 Cutter Chain	8-53817

J-5 Parts—Foot Control



Photo 1

Foot Control—Photo 1

<u>Ref</u>	<u>Description</u>	<u>Part Number</u>
A	Snap link	105-0029
B	Caster	104-0018
C	Foot Cable	8-53807



Photo 2

Foot Control—Photo 2

<u>Ref</u>	<u>Description</u>	<u>Part Number</u>
A	Rollers	8-44776
B	Storage Tray	8-46952
C	Load Chain Cover	8-46957
D	Electrical Box Cover	8-46966
E	Foot Cable Switch	8-43411

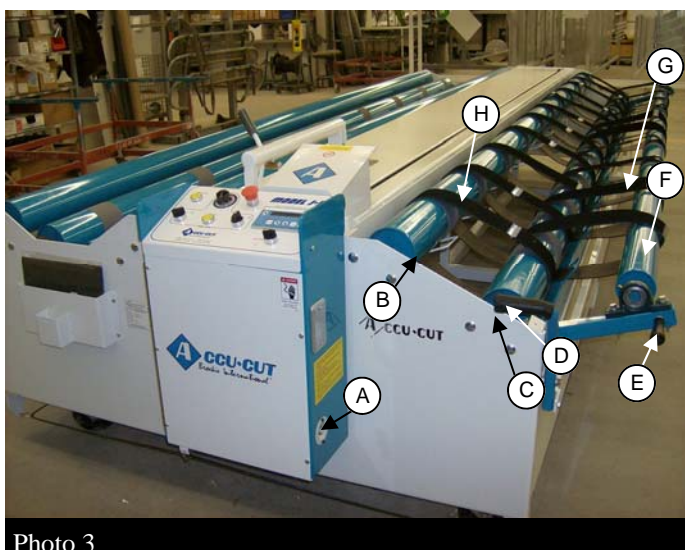

Photo 3

Foot Control—Photo 3

<u>Ref</u>	<u>Description</u>	<u>Part Number</u>
A	Extension Cord	8-53666
B	Rollup Chain Cover	8-46956
C	Dump Handle	8-46968
D	Rubber Handle	206-0071
E	Handle	7-1160
F	Roller 3 1/2"	8-44775
G	Outer Rollup Belt	8-53806
H	Inner Rollup Belt	8-53805
	Grip Tape 3 1/2" Roller	8-53804

J-5 Parts—Rollup Cradle

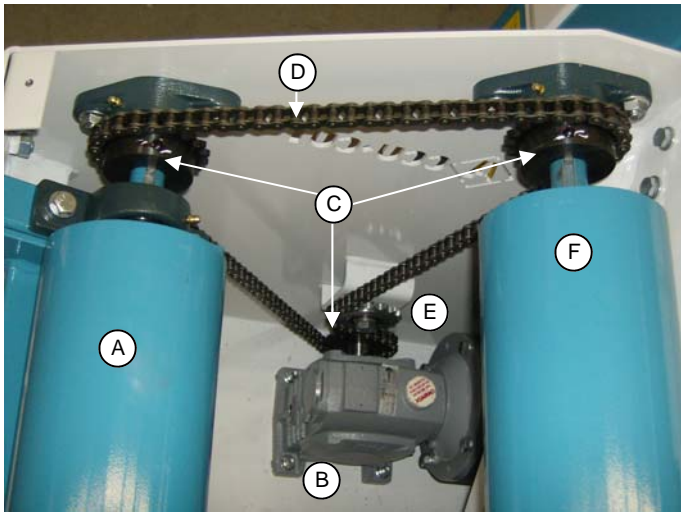

Photo 1

Rollup Cradle—Photo 1

<u>Ref</u>	<u>Description</u>	<u>Part Number</u>
A	Foldup Roller 5"	8-44774
B	Gearbox	107-0012
C	Sprocket	120-0042
D	Rollup Drive Chain	8-53793
E	Idler	120-0039
F	Roller 5"	8-44776

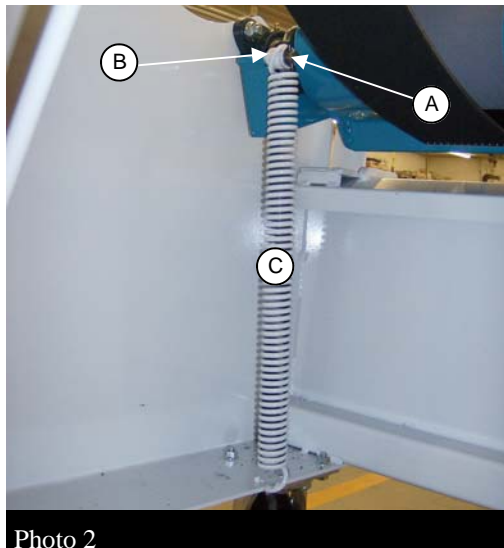

Photo 2

Rollup Cradle—Photo 2

<u>Ref</u>	<u>Description</u>	<u>Part Number</u>
A	Rollpin	113-0028
B	Spring Sleeve	8-48246
C	Foldup Spring	119-0018

J-5 Parts—Electrical

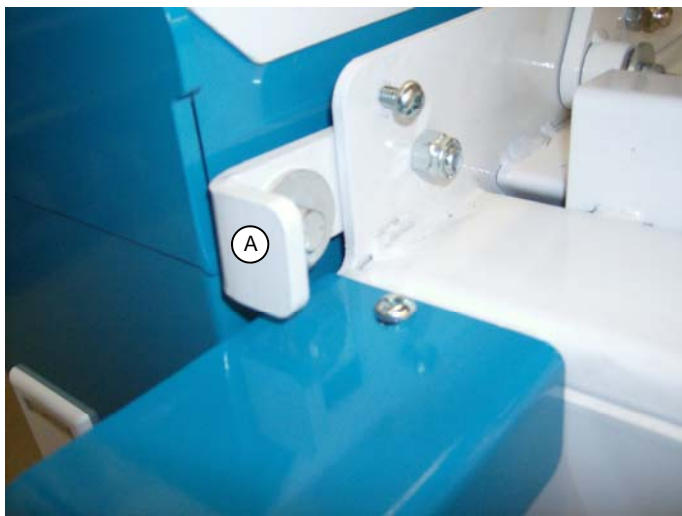

Photo 1

Electrical—Photo 1

<u>Ref</u>	<u>Description</u>	<u>Part Number</u>
A	Electrical Box Latch	8-3671

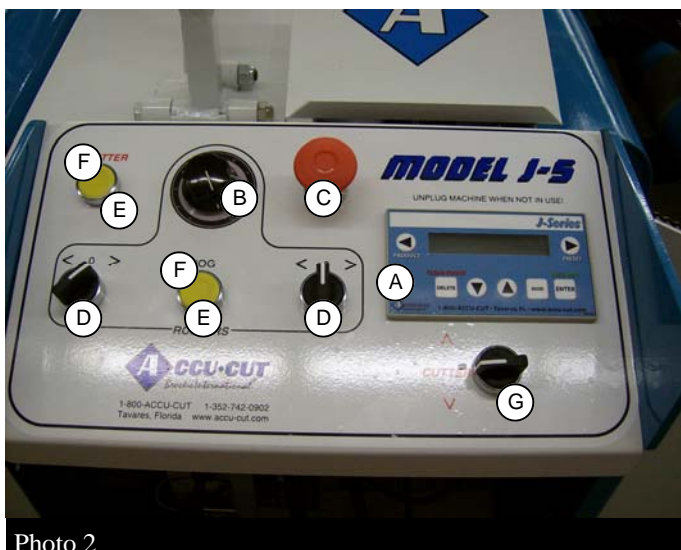

Photo 2

Electrical—Photo 2

<u>Ref</u>	<u>Description</u>	<u>Part Number</u>
A	Interface	409-0057
B	Speed Control Knob	410-0009
C	Emergency Stop Switch	410-0056
D	3-Way Switch maintained	410-0057
E	Push Button	410-0054
F	Yellow Insert	410-0055
G	3-way switch momentary	410-0058

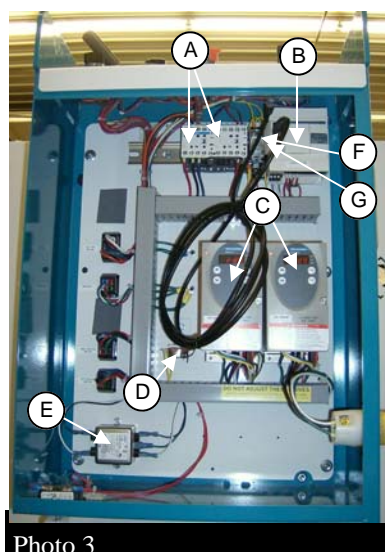
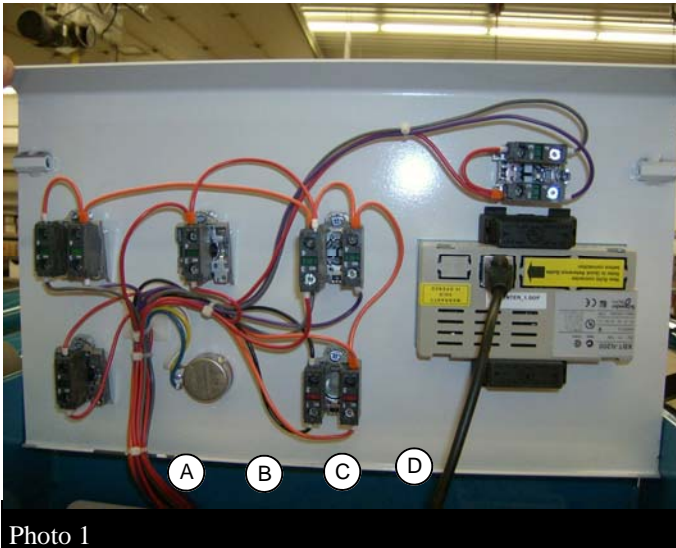

Photo 3

Electrical—Photo 3

<u>Ref</u>	<u>Description</u>	<u>Part Number</u>
A	Reversing Contactor	409-0031
B	Tele PLC	409-0055
C	Drive 1HP	403-0015
D	Speed Control	410-0013
E	Line Filter	406-0007
F	Relay	409-0021
G	Relay Base	409-0022

J-5 Parts—Electrical



Electrical—Photo 1

<u>Ref</u>	<u>Description</u>	<u>Part Number</u>
A	Speed Control	410-0013
B	Contact Block No	410-0060
C	Mounting Collar	410-0059
D	Contact NC	410-0061

J-5 Parts—Brakes

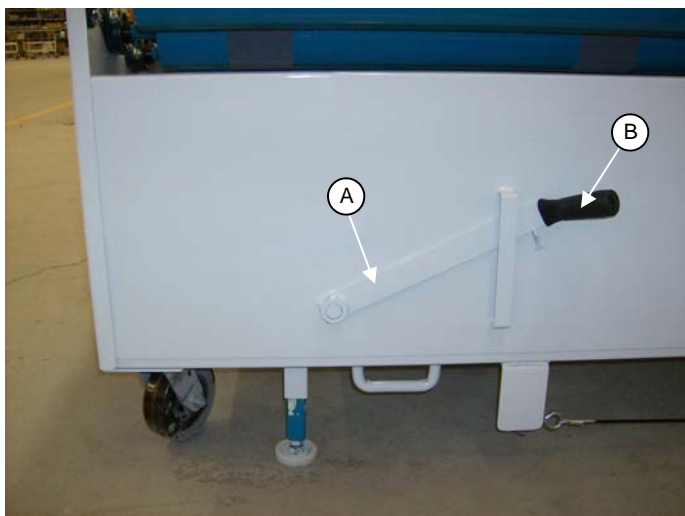

Photo 1

Brakes—Photo 1

<u>Ref</u>	<u>Description</u>	<u>Part Number</u>
A	Brake Handle	8-53783
B	Rubber Hold Grip	206-0071

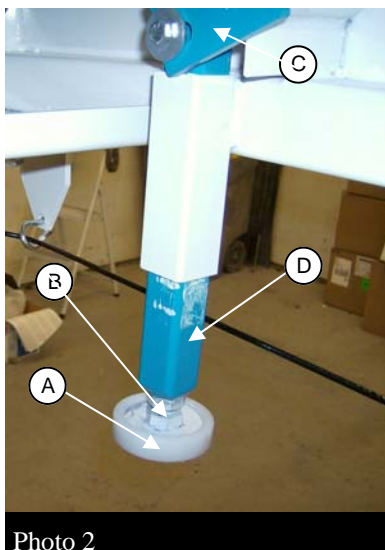

Photo 2

Brakes—Photo 2

<u>Ref</u>	<u>Description</u>	<u>Part Number</u>
A	Brake Shoe Plastic	8-48615
B	Brake Foot Assembly	8-49526
C	Brake Cam	
	Left	8-53781
	Right	8-53787
D	Brake Leg Assembly	8-46933



Brockie International, Inc.
28114 CR 561
Tavares, Florida 32778
352-742-0902 / 800-222-8288